

ITEM NO.	PART NUMBER	DESCRIPTION	MATERIAL	Default/ QTY.
1	OP00101	HANDLE	304 SS	1
2	OP00103	BOTTLE OPENER	304 SS	1
3	OP00102	EXTRACTION LEVER	304 SS	1
4	OP00104	SUPPORT PLATE	304 SS	2

REVISIONS				
REV.	DESCRIPTION	DATE	BY	APPROVED

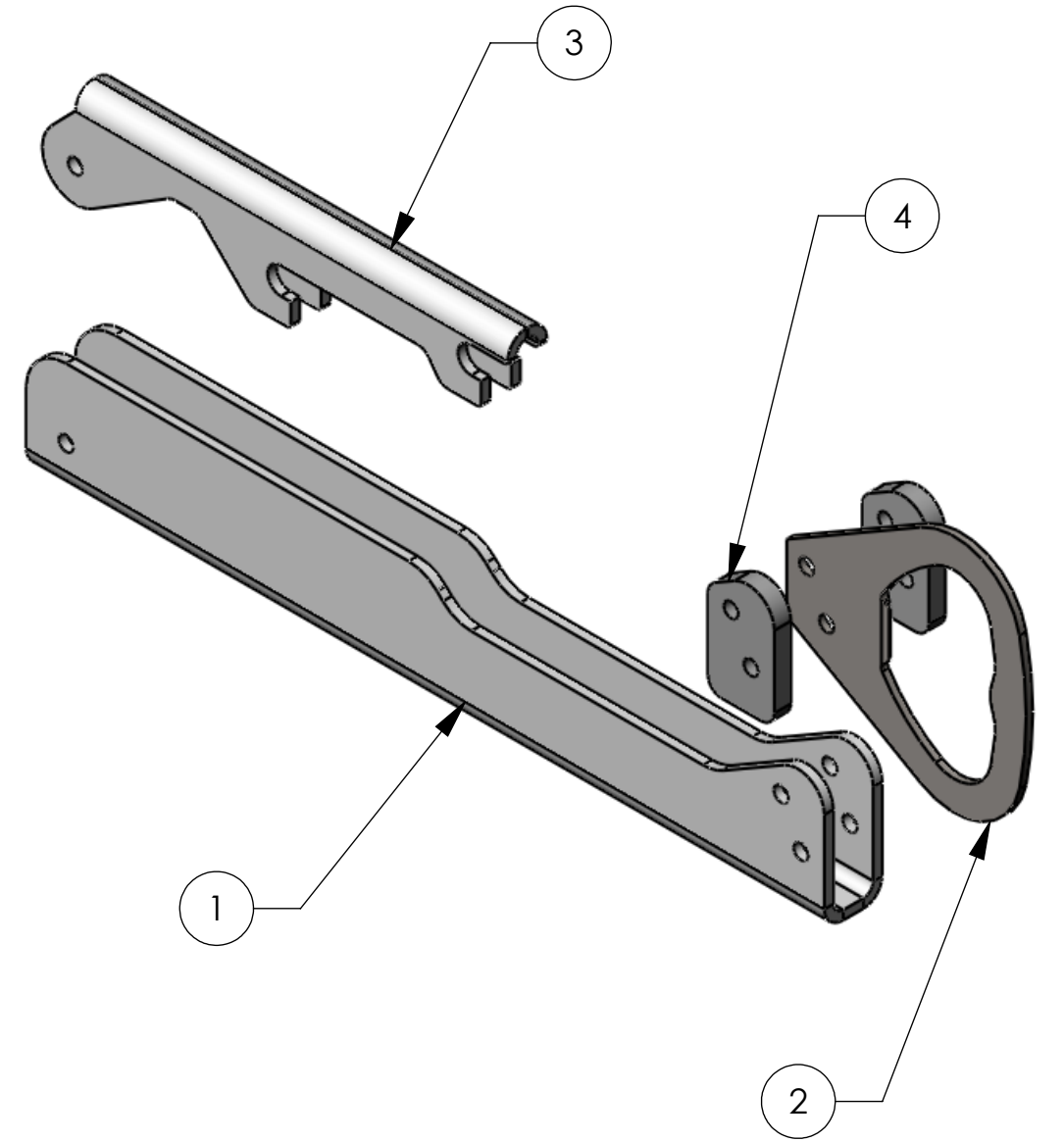
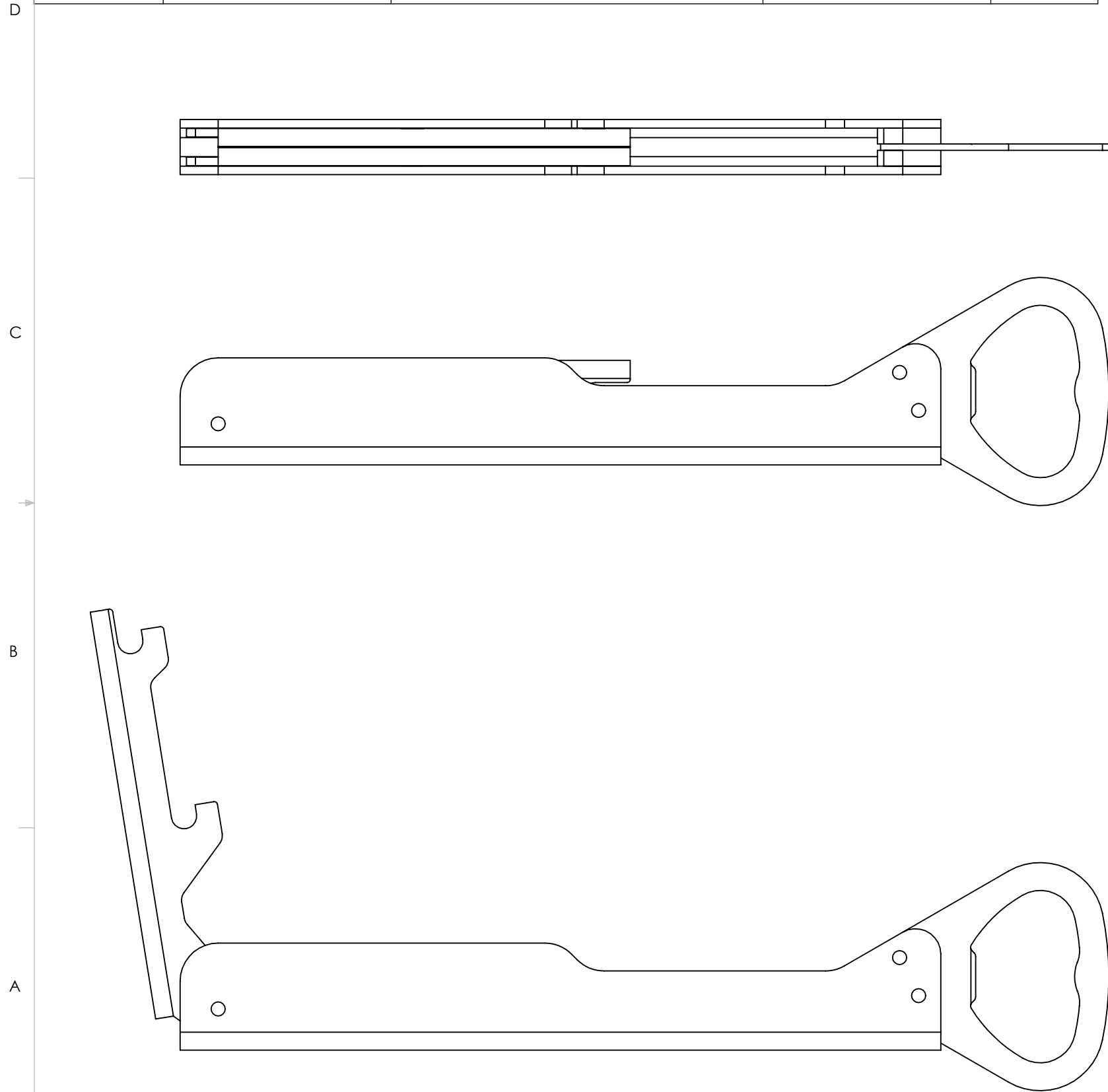

UNLESS OTHERWISE SPECIFIED:		DRAWN	-	-	DESCRIPTION: OPENER
DIMENSIONS ARE IN INCHES TOLERANCES:		CHECKED	-	-	
ANGULAR: MACH ± .5° BEND ± 1°		SCALE: 1:1			SIZE
TWO PLACE DECIMAL ±.010		COMMENTS:			PART NO.
THREE PLACE DECIMAL ±.005					REV
MATERIAL	-	THIRD ANGLE PROJECTION			SHEET 1 OF 1
FINISH	-				

REVISIONS				
REV.	DESCRIPTION	DATE	BY	APPROVED

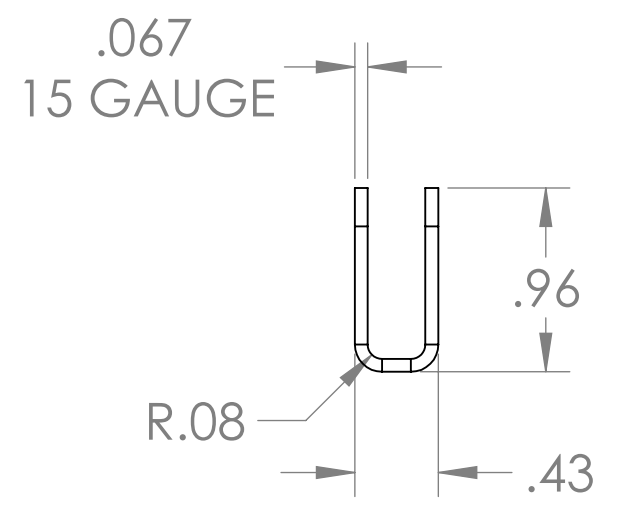
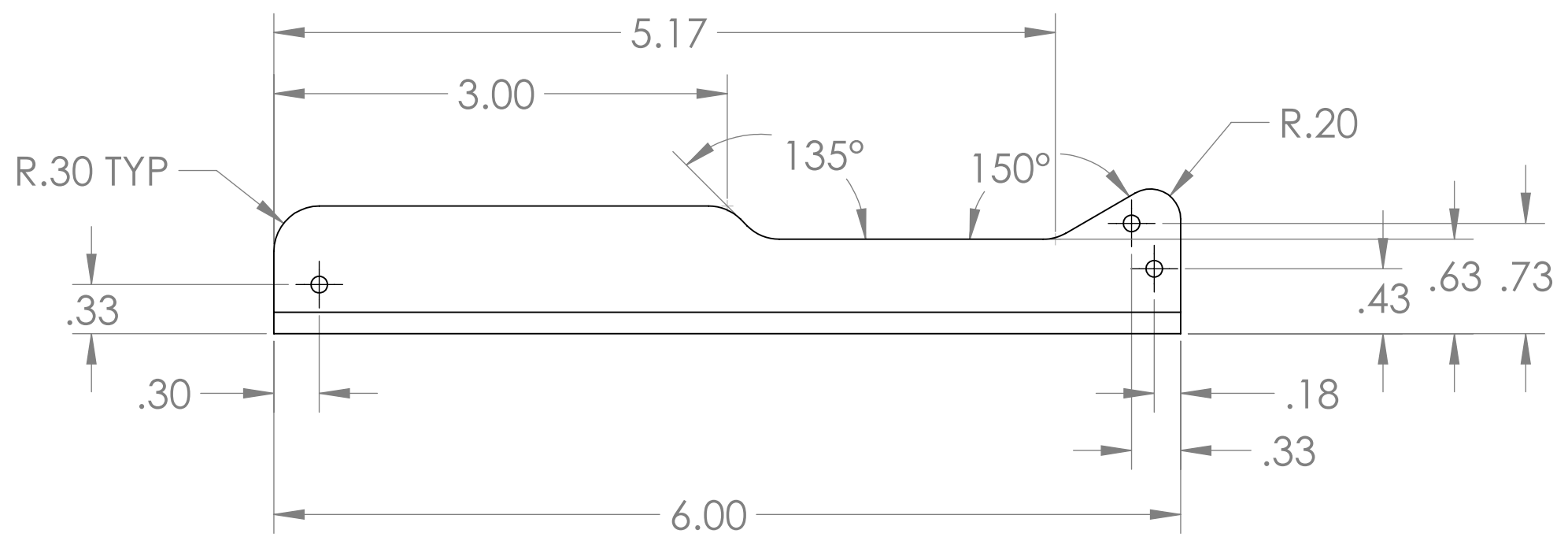
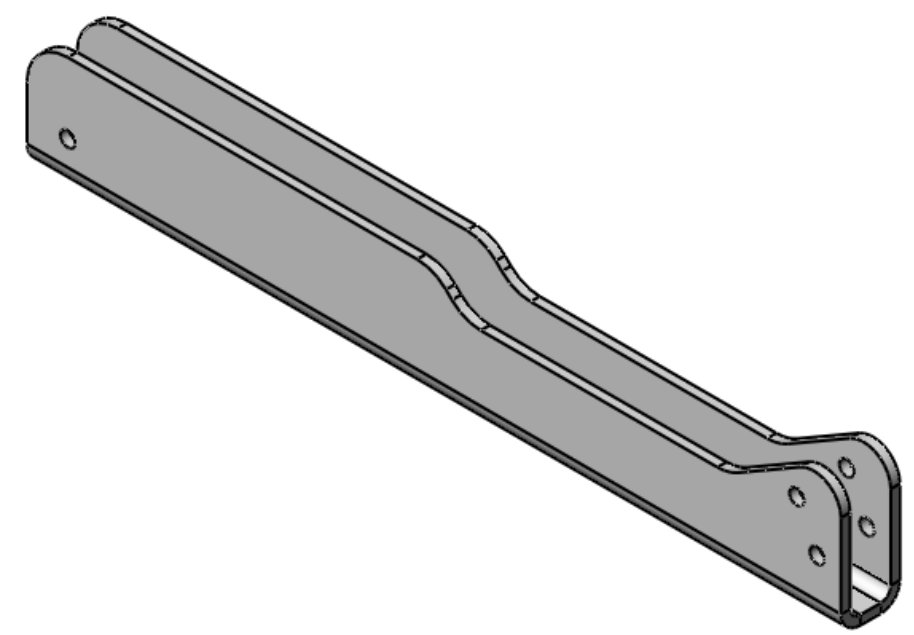

UNLESS OTHERWISE SPECIFIED: DIMENSIONS ARE IN INCHES TOLERANCES: ANGULAR: MACH ± .5° BEND ± 1° TWO PLACE DECIMAL ± .010 THREE PLACE DECIMAL ± .005 MATERIAL 304 SS FINISH -	DRAWN	-	-	DESCRIPTION: HANDLE	
	CHECKED	KL	-		
	SCALE: 1:1			SIZE	PART NO.
	COMMENTS:			B	-
THIRD ANGLE PROJECTION				SHEET 1 OF 1	

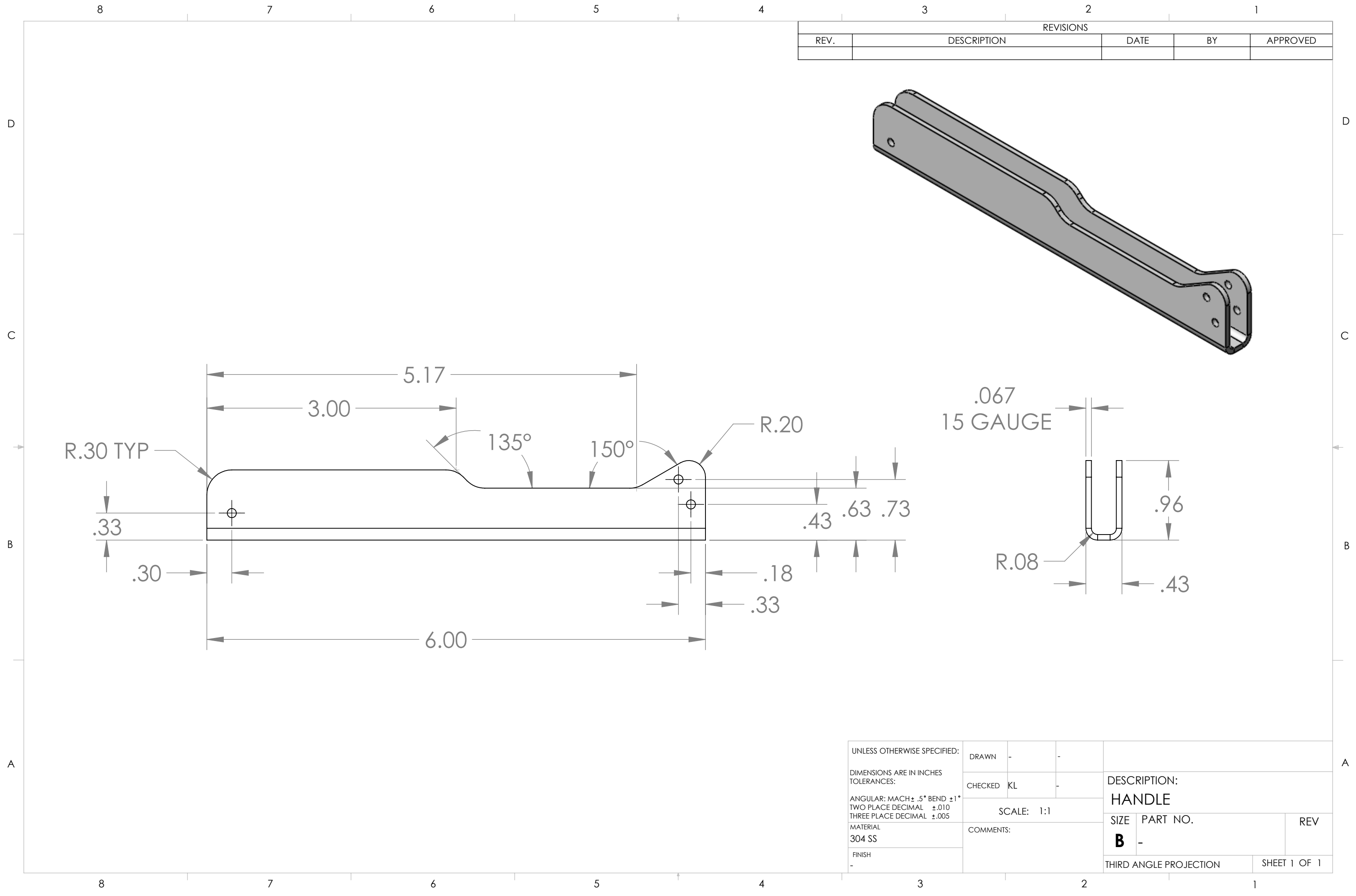

8 7 6 5 4 3 2 1

REVISIONS				
REV.	DESCRIPTION	DATE	BY	APPROVED

D
C
B
A

D
C
B
A

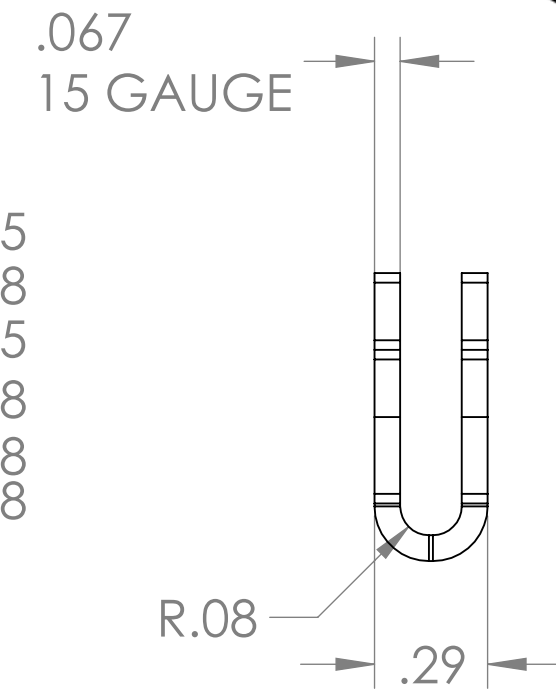
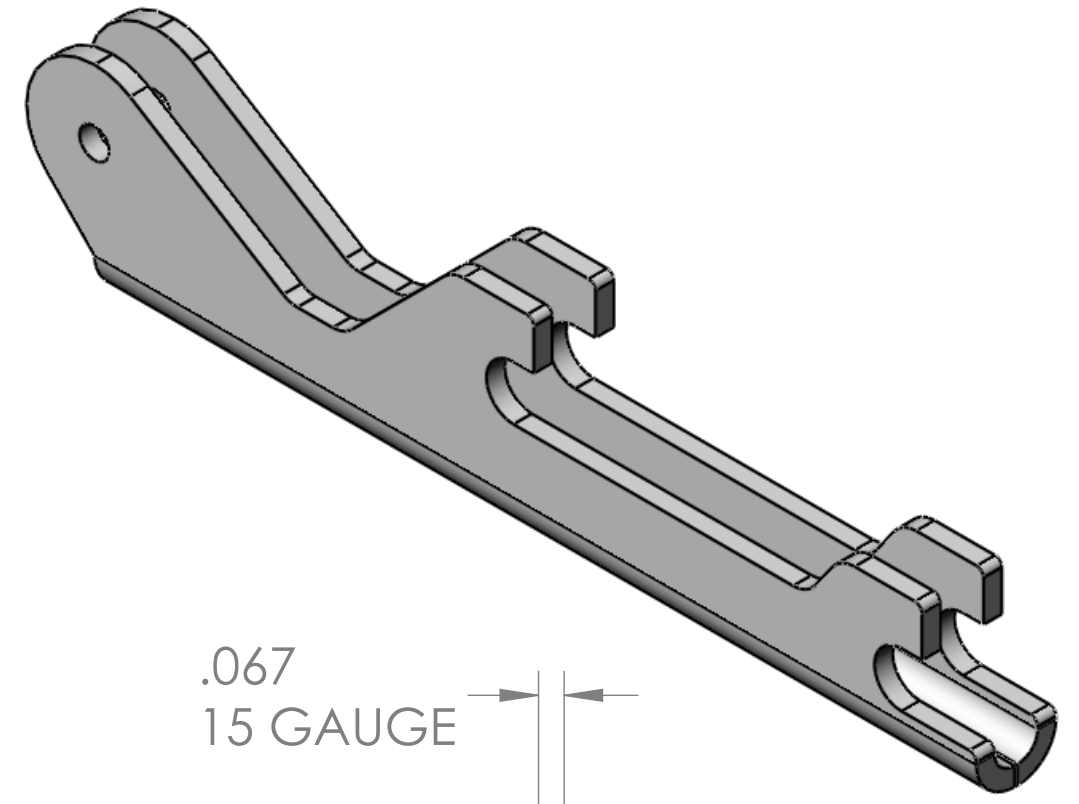
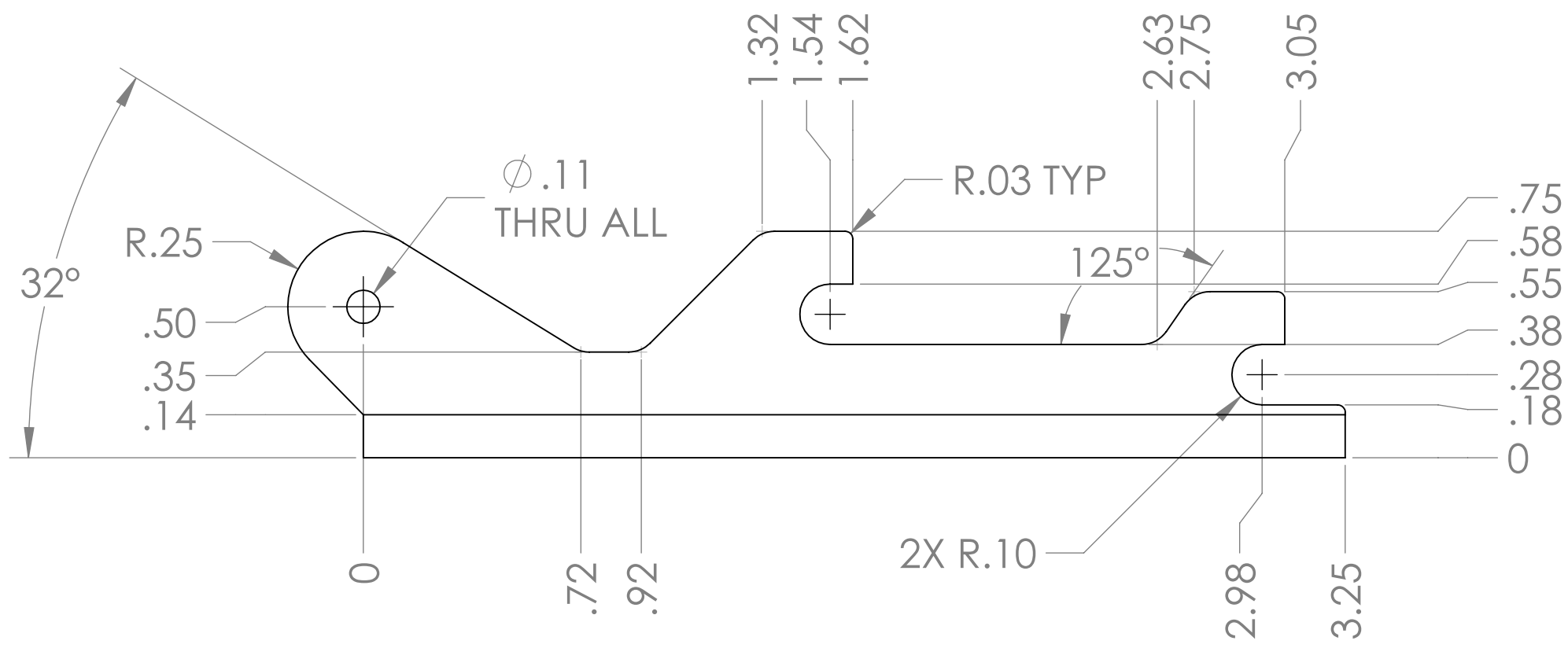

UNLESS OTHERWISE SPECIFIED: DIMENSIONS ARE IN INCHES TOLERANCES: ANGULAR: MACH ± .5° BEND ± 1° TWO PLACE DECIMAL ± .010 THREE PLACE DECIMAL ± .005 MATERIAL 304 SS FINISH -	DRAWN	-	-	DESCRIPTION: EXTRACTION LEVER	
	CHECKED	KL	-		
	SCALE: 2:1			SIZE	PART NO.
	COMMENTS:			B	REV
THIRD ANGLE PROJECTION				SHEET 1 OF 1	

8 7 6 5 4 3 2 1

8 7 6 5 4 3 2 1

REVISIONS				
REV.	DESCRIPTION	DATE	BY	APPROVED

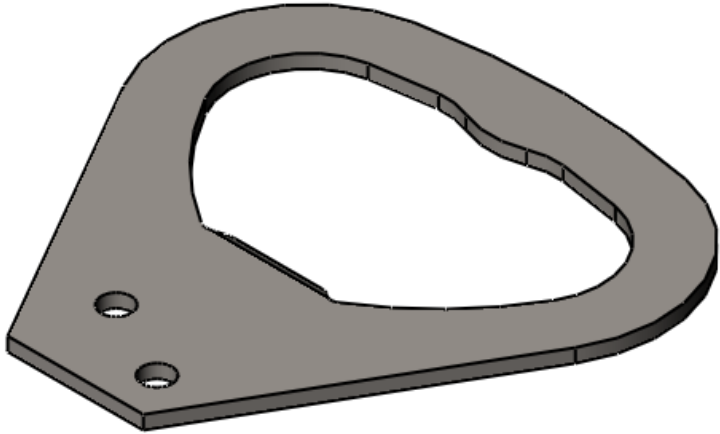
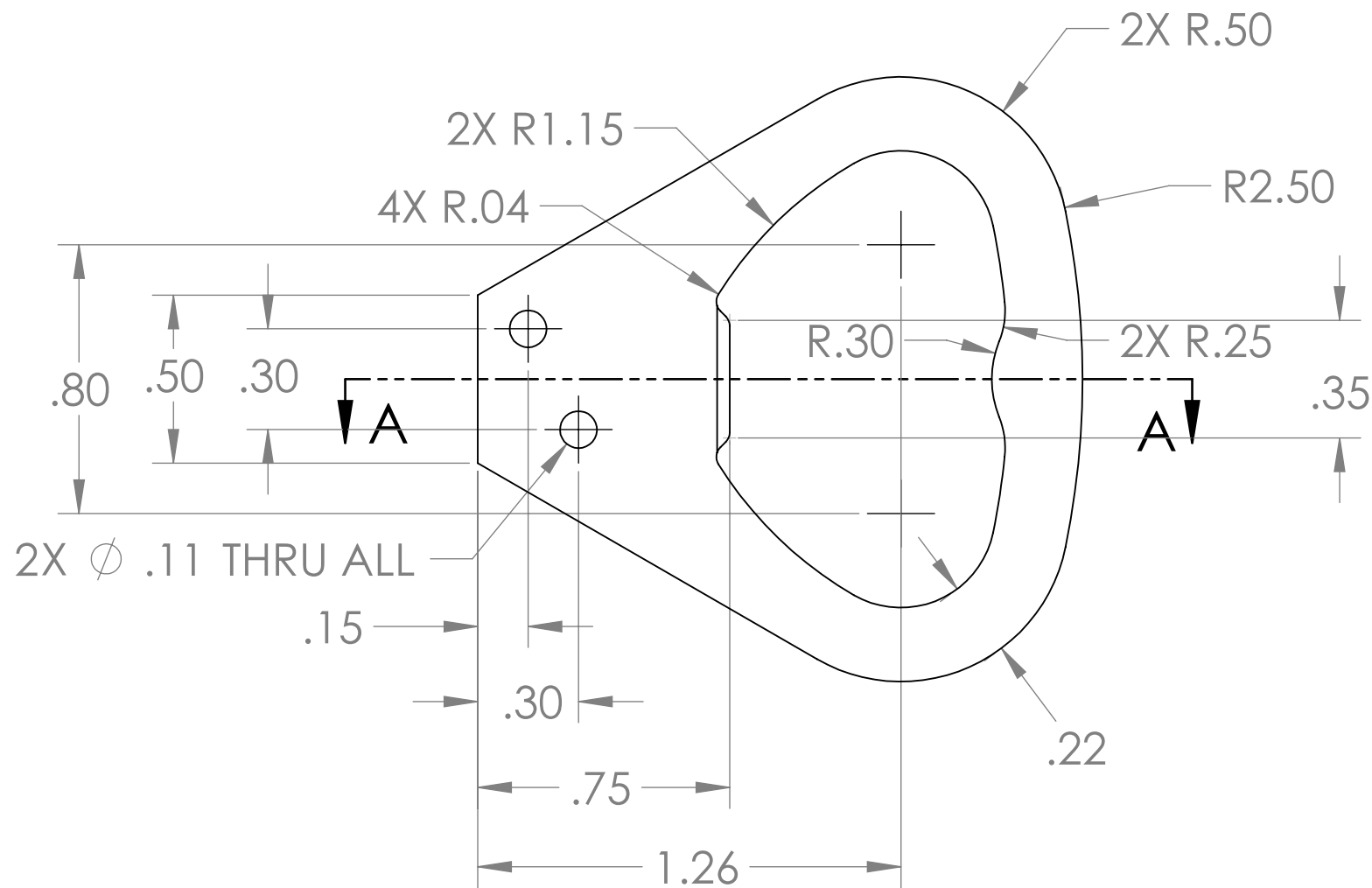
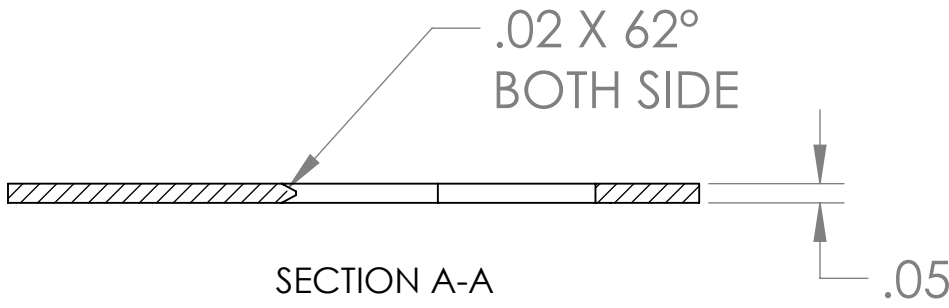

UNLESS OTHERWISE SPECIFIED: DIMENSIONS ARE IN INCHES TOLERANCES: ANGULAR: MACH ± .5° BEND ± 1° TWO PLACE DECIMAL ± .010 THREE PLACE DECIMAL ± .005 MATERIAL 304 SS FINISH -	DRAWN	-	-	DESCRIPTION: BOTTLE OPENER	
	CHECKED	KL	-		
	SCALE: 2:1			SIZE	PART NO.
	COMMENTS:			B	REV
THIRD ANGLE PROJECTION				SHEET 1 OF 1	

8 7 6 5 4 3 2 1

8 7 6 5 4 3 2 1

REVISIONS				
REV.	DESCRIPTION	DATE	BY	APPROVED

D
C
B
A

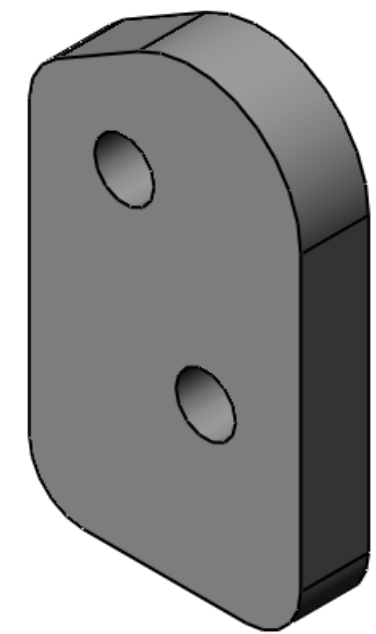
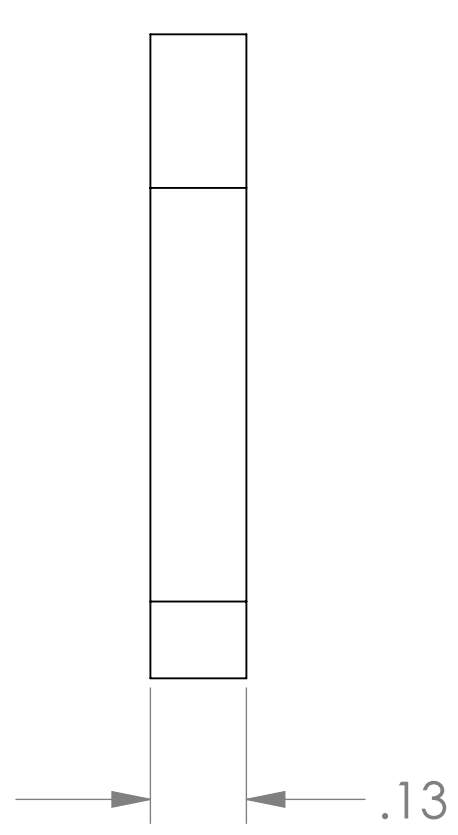
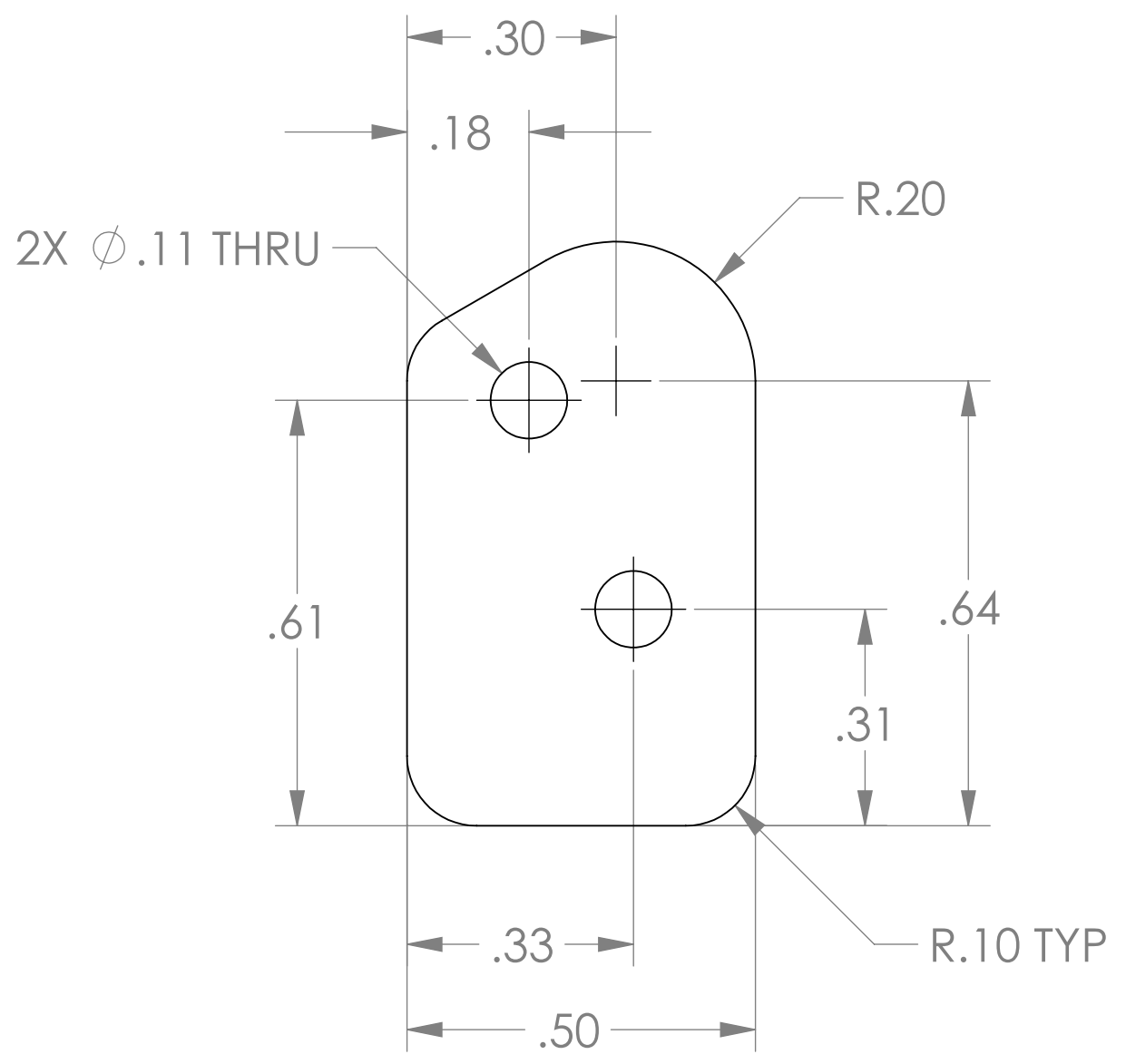

D
C
B
A

8 7 6 5 4 3 2 1

UNLESS OTHERWISE SPECIFIED: DIMENSIONS ARE IN INCHES TOLERANCES: ANGULAR: MACH ± .5° BEND ± 1° TWO PLACE DECIMAL ± .010 THREE PLACE DECIMAL ± .005 MATERIAL 304 SS FINISH -	DRAWN	-	-	DESCRIPTION: SUPPORT PLATE	
	CHECKED	KL	-		
	SCALE: 4:1			SIZE	PART NO.
	COMMENTS:			B	-
THIRD ANGLE PROJECTION				REV	
SHEET 1 OF 1					